

EOP5-057 Series Human Machine Interface HMI

EOP5-057AT, EOP5-057AT-DP, EOP5-057AT-CAN, EOP5-057AT-MPI

Installation Instructions



1.0 Installation Overview

1.1 Environment requirements

Where Used	EOP5-057 series is designed for factory application. Its operating temperature ranges from -10~70°C. It may not be suitable for use in certain outdoor applications. Please consult your suppliers for advised usage in outdoor applications.
NEMA rating	EOP5-057 series front panel is NEMA 4 rated. When installed properly in a NEMA 4 panel, the NEMA 4 rating of the panel will not be compromised. It means that fluids will not enter the panel during wash downs.
Electrical environment	EOP5-057 series has been tested to conform to European CE requirements. Proper wire routing and grounding will insure proper operation.
Mechanical environment 	Keep installing units from environments where severe mechanical vibration or shocks are present.

2.0 Installation Description

2.1 Mounting Instructions

2.1.1 Location Considerations

Care should be taken when locating equipment behind the unit to ensure that AC power wiring, PLC output modules, contactors, starters and relays, and any other source of electrical interference are located away from the back of the unit.

2.1.2 Making a NEMA-4 Mounting





Panel Details	The EOP5-057 series can be mounted into panels with a depth of over 105mm. It is recommended that the unit be mounted on the front panel of a steel enclosure, through an appropriate opening. Allow a clearance of at least 25mm around the sides of the unit for mounting hardware. Allow clearance for cable connections to the back of the unit. Unit depth may vary according to cable type used. Typically, plan a depth to accommodate at least 105mm behind the panel.
NEMA-4 Mounting	Put the unit through the panel cut out. Slide the clamps into the 4 holes provided around the case. Tighten the clamping screws in an even pattern until the unit is secured in the panel.
Caution!	Do not over-tighten mounting clamps!
Note:	Specifications: To seal to NEMA-4 specifications, all supplied mounting clamps must be used and do not flex panel.

2.1.3 Environmental Considerations

	<ul style="list-style-type: none"> ● The EOP5-057 series is to be used indoors as built in displays. Make sure that the displays are installed correctly and that operating limits are followed (See Hardware Specifications). ● Do not operate the unit in areas subject to explosion hazards, flammable gases, vapors or dusts. ● The unit should not be installed where fast temperature variation or high humidity is present. This will cause condensation of water in the device and damage it.
--	--

2.2 Power Connections

2.2.1 Power Requirements

	Power Supply	Input voltage: 24V DC \pm 15%
	Fusing Requirement	If the display does not come on within 2 seconds of power-up, turn off the power immediately. An internal fuse will prevent damage if the polarity of the DC power is incorrect. Check wiring to ensure proper connections and try to power up again.
	Caution! High Voltage	An Internal fuse will prevent damage for over voltage condition, however it isn't guaranteed the internal electronic components are not damaged. DC sources should provide proper isolation from main AC power.
	Caution! Emergency Stop	A hard-wired Emergency Stop should be fitted in any system using the EOP5-057 to comply with the ICS Safety Recommendations.
	Caution! Supply Voltage Condition	Do not power the EOP5-057 and inductive loads, or input circuitry to the controller, with the same power supply. Note: The 24V DC output from some controllers may not have enough current to power the EOP5-057.

	<p>Caution! Wire Routing</p>	<p>Wire lengths of DC power should be minimized (Maximum 500m (shielded), 300m (unshielded twisted pairs)). Twisted pairs are recommended for use. If the wiring is to be exposed to lightning or surges, take appropriate lightning protection measures. Keep dynamical power far away from communication cable. Equip ungrounded DC supplies with a resistor and capacitor in parallel to earth ground. This provides a path for static and high frequency dissipation. Typical values to use are 1MΩ and 4700pF.</p>
	<p>Connection</p>	<p>For power cables, please select cables with their dielectric strength values and current values in compliance with the safety specifications. Power terminals are packed inside the packaging box. Connect positive DC line to the '+24V' terminal and the DC ground to the '0V' terminal.</p>

2.2.2 Grounding Requirements



	<p><u>Chassis ground must be used.</u> DC ground is not directly coupled to earth ground internally. It is preferable not to ground DC negative return to chassis ground as poor site earths can introduce noise into a system, but if necessary an earth connection should be made, from the power supply return point to the star earth point, ground conductors should be as short and as large in cross-sectional area as possible, the conductors should be able to carry the maximum short circuit current. Ground conductors should be connected to a star earth point. This ensures that no ground conductor carries current from any other branch.</p>
--	--

2.2.3 CE Requirements

To make the EOP5-057 series comply with EMC directives, and to reduce susceptibility to electrical interference, a separate #14 AWG ground wire should be taken to the chassis ground terminal of the power connector. This ground connection should be run directly to the star earth connection point.

2.2.4 Safety Guidelines

This section presents recommended installation practices and procedures. Since no two applications are identical, these recommendations should be considered as guidelines.

<p>Hardware Considerations</p> 	<p>Caution! The system designer should be aware that devices in controller systems could fail and thereby create an unsafe condition.</p>
<p>Programming Precaution</p> 	<p>To conform to ICS Safety Recommendations, checks should be placed in the controller to ensure that all writable registers that control critical parts of plant or machinery have limit checks built into the program, with an out-of-limit safe shutdown procedure to ensure safety of personnel.</p>

ICS 3-304.81 Safety Recommendations:

Consideration should be given to the use of an emergency stop function, which is independent of the programmable controller.

Where the operator is exposed to the machinery, such as in loading or unloading a machine tool, or where the machine cycles automatically, consideration should be given to the use of an electromechanical override or other redundant means, independent of the programmable controller, for starting and interrupting the cycle.

If provision is required for changing programs while the equipment is in operation, consideration should be given to the use of locks or other means of assuring that only authorized personnel can make such changes.

- These recommendations are intended as safeguards against the failure of critical components and the effects of such failures or the inadvertent errors that might be introduced if programs are changed while the equipment is in operation.

- The ICS 3-304.81 Safety Recommendations are reproduced by permission of the National Electrical Manufacturers Association from NEMA ICS 3-304.

2.3 Communication Connections and Other Fittings

The ports as you look at the back of the case, are the ports for connecting to a Printer, PC, a PLC or some other peripherals (such as Controller Connectors).

2.3.1 Connection with External Devices

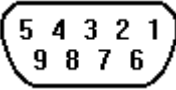
Cable requirements	Different cables are required for various external devices.
Precaution Caution! Do no insert or pull out the cable while the power is on.	Restrict cable length to less than 150m for Rs-485/422 devices and 15m for RS-232 devices to avoid communications problems. Communications problems cause the display to show “PLC no response...” until communications can be established. The COM light on the front of the EOP5-057 will turn on with each communication. Shielded cables must be used for long lengths or cables run in an electrically noisy environment. Do not run cables next to AC power lines or near sources of electrical noise. Be sure that the cable ends have been inserted all of the way into mating connectors and are secure.
Pin Designations  COM0 & COM2	Pin assignment of the 9-pin male, D-SUB, COM0. This port is used to connect the EOP5-057 series to controller with RS-232/485/422 port. Note: RS232/485/422 communication functions are supported by COM0. COM2 supports RS232 communication function, not only can connect with the controller of RS232, but also can be used in HMI program downloading and debugging.

Pin	Symbol	PLC [RS-485]4 wire	PLC [RS-485]2wire	PLC [RS-232]	PC[RS-232]
1	Rx-(A)	RS-485 Rx	RS485A		
2	RxD_PLC			RS-232 Rx	
3	TxD_PLC			RS-232 Tx	
4	Tx-	RS-485 Tx			
5	GND	Signal ground			
6	Rx+(B)	RS-485 Rx	RS485B		
7	RxD_PC				RS-232 Rx
8	TxD_PC				RS-232 Tx
9	Tx+	RS-485 Tx			

Pin Designations

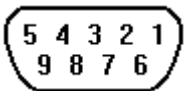

COM1

Pin assignment of the 9-pin female, D-SUB, COM1. This port is used to connect the EOP5-057 series to controllers with RS-232/485/422 port.

Pin	Symbol	PLC [RS-485]4 wire	PLC [RS-485]2 wire	PLC [RS-232]
1	Rx-(A)	RS-485 Rx	RS485A	
2	RxD_PLC			RS-232 Rx
3	TxD_PLC			RS-232 Tx
4	Tx-	RS-485 Tx		
5	GND	Signal ground		
6	Rx+(B)	RS-485 Rx	RS485B	
7	CTS_PLC			Clear to send input
8	RTS_PLC			Ready to send output
9	Tx+	RS-485 Tx		

2.3.2 Connection with PC

The COM0 port on the back of the case can be used to connect RS232/RS485/RS422 devices and can also be used to connect with the programming interface and setting interface of a PC.

Connection	The port can be attached to PC via a dedicated cable (P/N: MT54-PC).
Port Function	Due to the reason of communication rate, the COM0 is only used for configuration-download and parameter-setting, and it can not be used for indirect online simulation.

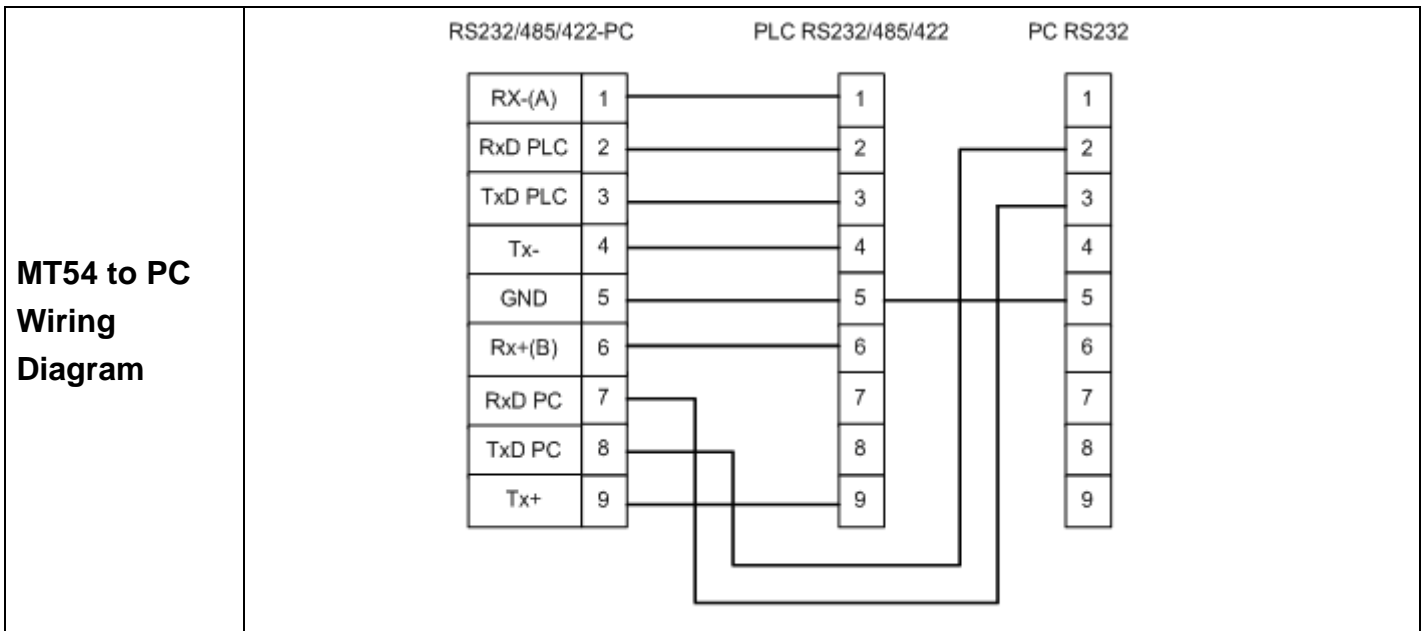

2.3.3 USB Connection

The USB port on the back of the case is the USB Slave device used to connect with a PC for configuration downloading and HMI setting. It cannot be used to connect with peripheral equipment such as the USB printer.

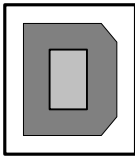
Connection	USB Slave port can be connected with a PC through a general USB cable.
Port Function	The port is only used to download user configuration program to the HMI and to set HMI system parameters.
Port Diagram	

2.3.4 Ethernet Connection

The Ethernet interface on the back of the product enclosure is a 10M/100M adaptive Ethernet port.

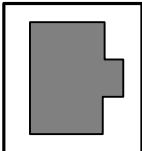
Connection	This port is connected with the HUB or Switch through a standard Ethernet cable (RJ-45 straight-through cable) and then connected to a LAN. It can also be directly connected with the Ethernet port of a PC through a dual system interconnection cable (RJ-45 crossover cable).
Port Function	The port can be used for upload/download of HMI configuration, setting of system parameters and online simulations of configurations. It can connect multiple HMIs via the Ethernet to form an HMI network. Furthermore, it can implement communications between HMI and PLC via the Ethernet, as well as communications with a PC via the Ethernet port.
Port Diagram	

2.3.5 PROFIBUS-DP Interface

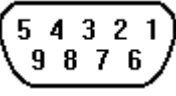
Connection	The port can be connected with other equipments via a dedicated PROFIBUS-DP communication cable.			
Port Function	EOP5–057series HMIs can be connected to PROFIBUS-DP network via a PROFIBUS-DP expansion board, Thus, data can be exchanged between HMIs and other equipments via fieldbus.			
Pin Designations  Field Bus 0	Pin assignment of the 9-pin female, D-SUB, Profibus-DP.			
	Pin	Symbol	RS-485	Description
	1			
	2			
	3	RXD/TXD_P	B/B'	Receiving / Sending data_P
	4	CNTR_P (1)		Control Signal_P
	5	DGND	C/C'	Signal ground
	6	VP (2)		Positive voltage
	7			
	8	RXD/TXD_N	A/A'	Receiving / Sending data_N
	9	CNTR_N (1)		Control Signal_N
Note: (1)'s signal is optional. (2)'s signal is only needed at the site of bus cable port.				

2.3.6 CANbus Interface

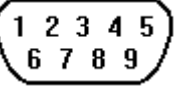
Connection	The port can be connected with other equipments via a dedicated cable.		
Port Function	EOP5–057 series HMIs can be connected to CANbus Network via an expansion board , Thus, data can be exchanged between HMIs and other equipments via fieldbus.		
Pin Designations  Field Bus 0	Pin assignment of the 9-pin male, D-SUB, CANbus.		
	Pin	Symbol	Description
	1		
	2	CAN_L	CAN_L bus line dominant low
	3	CAN_GND	Signal ground
	4		
	5		
	6		
	7	CAN_H	CAN_H bus line dominant high
	8		
9			

2.3.7 MPI Interface

Connection	The port can be connected with other equipments via a dedicated cable.
Port Function	EOP5–057 series HMIs can be connected to MPI Network via an expansion board , Thus, data can be exchanged between HMIs and other equipments via fieldbus.

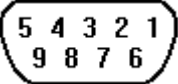
Pin Designations  Field Bus 0	Pin assignment of the 9-pin female, D-SUB, MPI.			
	Pin	Symbol	RS-485	Description
	1			
	2			
	3	RXD/TXD_P	B/B'	Receiving / Sending data_P
	4			
	5	DGND	C/C'	Signal ground
	6			
	7			
	8	RXD/TXD_N	A/A'	Receiving / Sending data_N
9	RTS		Control Signal	
Note: MPI_RTS connect with the pin-9 of the SIEMENS_PLC terminal				

2.3.8 USB HOST Interface

Connection	Connect with USB interface devices or U disks
Port Function	This interface can be connected with USB keyboard, mouse and printers, and the U disk can be used for user's configuration uploading/ downloading as well as data storage.
Port Diagram	

2.3.9 Audio Interface

Connection	Standard 3.5mm Audio Output Interface
Port Function	Audio Files are added in the configuration in advanced, the audio signal will produced when specific events occurred.
Port Diagram	

2.3.10 SD Card's Extended Interface

Connection	Standard SD card interface
Port Function	The SD Card can be inserted in through this interface for Data storage and user configuration uploading/downloading.
Port Diagram	

2.3.11 DIP Switch

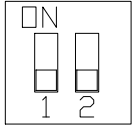

SW1	SW2	Working Mode
ON	ON	System Setting Mode
OFF	ON	Touch Screen Calibrate Mode
ON	OFF	Firmware Update and Basic Parameter Setting Mode
OFF	OFF	Application (Online Operation) Mode

- **System Setting Mode:** In this mode, the HMI will start a built-in system setting interface, where you can set parameters such as date, startup interface, brightness and buzzer.
- **Touch Screen Calibrate Mode:** Used to calibrate the touch screen.
- **Firmware Update and Basic Parameter Setting Mode:** This mode is for senior user to update the system, if you are stranger, please consult supporter.
- **Application (Online Operation) Mode:** This is the normal working mode of EOP5–057 series. The HMI will start from the startup window of the project downloaded.

3.0 Product Specifications

3.1 Basic Parameters

Model	EOP5-057AT	EOP5-057AT-DP	EOP5-057AT-CAN	EOP5-057AT-MPI
Performance specification				
Display	5.7 TFT			
Resolution	320*240			
Color	65536			
Backlight	1CCFL			
Brightness	500cd/m ²			
Backlight life	50000 hr.			
Touch Panel	4-wire precision resistance network			
Processor	32-bit RISC CPU 520MHz			
Memory	16M FLASH, 32M SDRAM			
Recipe memory & RTC	512KB & RTC			
Expandable memory	SD Card, U Disk			
Printer port	Connect a printer with a USB port via USB HOST port.			
Ethernet	10/100 Base-T			
Audio interface	No Support			
Program download	1 USB SLAVE port			
COM port	COM0:RS232/RS485-2/RS485-4, COM1:RS232/RS485-2/RS485-4, COM2:RS232			
USB Host	A Mouse, Keyboard and Printer, etc. which can be extended by USB port.			
Communication extending	No support	PROFIBUS-DP	CANOPEN	MPI expansion
Electrical specification				
Rated power	7.2 W			
Rated voltage	DC24V			
Input range	DC21~DC28V			
Momentary power-off	<5ms			
Insulation resistance	Greater than 50MΩ @ 500V DC			
Dielectric strength test	500 VAC 1 minute			
Structure specification				
Shell color	White			
Shell material	ABS			
Dimensions(mm)	204.0×150.0×56.7 mm			
Cutout size(mm)	192.0×138.0 mm			
Weight	0.96kg			
Environment specification				
Operating temperature	-10~70 ⁰ C			
Operating humidity	10~90% non-condensing			
Storage temperature	-30~80 ⁰ C			
Storage humidity	10~90% non-condensing			
Shockproof test	10~25Hz (X, Y, Z direction, 2G, 30 minutes)			
Cooling method	Natural air cooling			
Certification				
Degree of protection	IP65 (front panel)			
CE certification	Comply with EN61000-6-2:2005 and EN61000-6-4:2007standards			
FCC compatibility	Complies with FCC Class A			

4.0 Dimensional Drawing of EOP5-057

Unit: mm (inch)

Front View

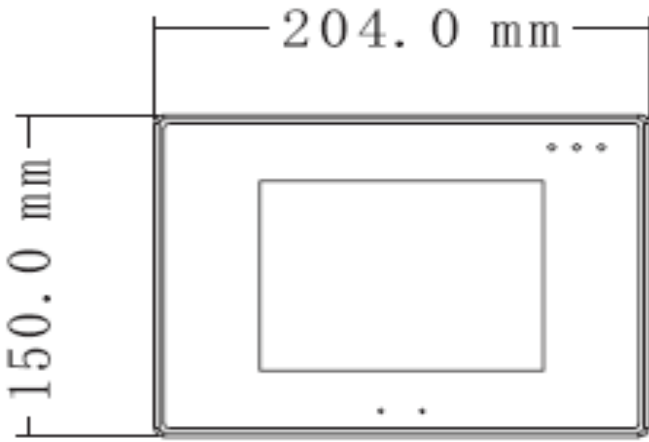

Side View

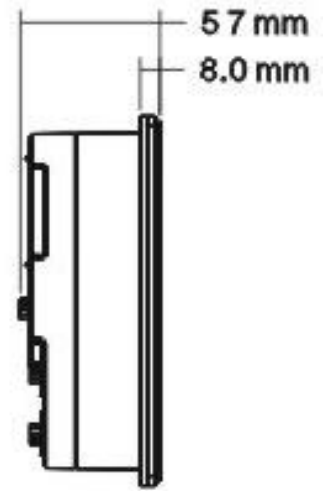

Top View

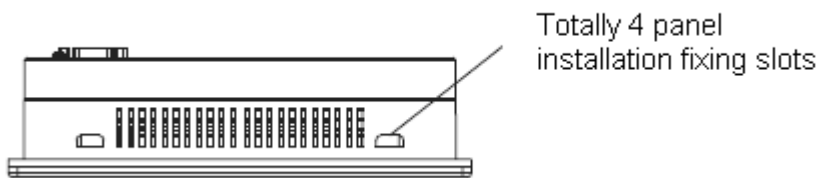

Rear View

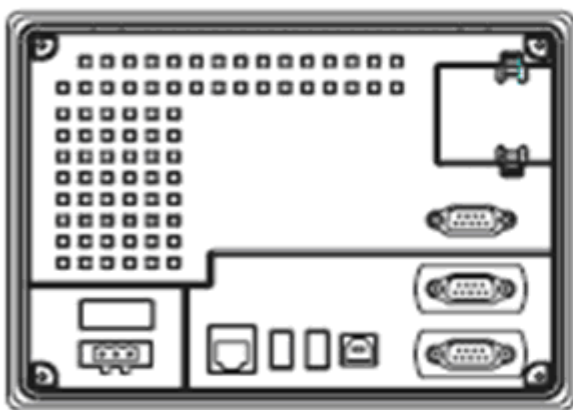

Cutout Size

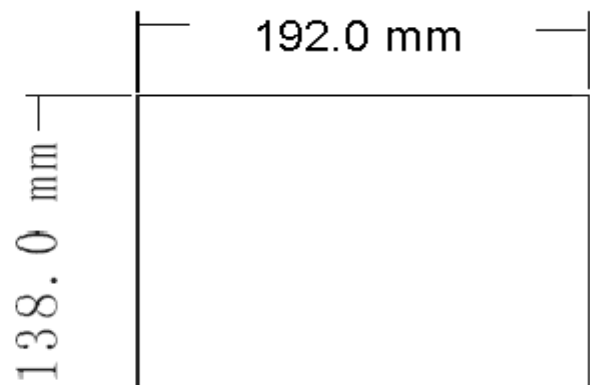

İmalatçı Firma:

Kinco Electric (Shenzhen) Ltd.

7/F, Bldg.9th,Software Park, Keji Central Road 2nd, Nanshan District, Shenzhen, China

Tel: 86-0755-26585555

Fax: 86-0755-26616372

İthalatçı Firma:

Sisel Mühendislik Elektronik San. ve Tic. A.Ş.

Yukarı Dudullu Barbaros Cad. Kutup Sok. No:20

34775 – Ümraniye / İstanbul – Türkiye

Tel: +90.216 499 46 64 pbx

Fax: 90.216 365 74 01



“**EN**inde sonun**DA**”

SİSEL MÜHENDİSLİK ELEKTRONİK SAN. VE TİC. A.Ş.

Yukarı Dudullu Barbaros Cad. Kutup Sok. No:20

34775 – Ümraniye / İstanbul – Türkiye

Tel: +90.216 499 46 64 pbx Fax: 90.216 365 74 01

Ofis gsm: +90.533 478 32 28

url: www.enda.com.tr E-mail: sisel@enda.com.tr

V01